

Ultrasonic flowmeters for liquids for permanent installation in hazardous areas

Features

- Two measuring channels
- Flameproof/explosion proof housing for hazardous areas
- Intrinsic safe process inputs for the integration of external pressure and temperature sensors
- More precise measurement at unfavorable measuring points through integrated disturbance correction
- Bidirectional communication and support of common bus technologies (Profibus PA, Foundation Fieldbus, HART, Modbus, BACnet)
- Certification: ATEX/IECEX zone 1, FM Class I Div. 1+2



Applications

- Chemical industry
- Petrochemical industry
- Oil and gas industry



Transmitter



Technical data

	FLUXUS F831 (831-AA*, 831-SA*)	FLUXUS F831 (831-AB*, 831-SB*)	FLUXUS F831 (831-ANN, 831-SNN)	FLUXUS F831**-F1N
				
design	831-AA* (aluminum housing): explosion-proof field device or 831-SA* (stainless steel housing): explosion-proof offshore device zone 1 (intrinsic safety: outputs, process interfaces)	831-AB* (aluminum housing): explosion-proof field device or 831-SB* (stainless steel housing): explosion-proof offshore device zone 1 (intrinsic safety: outputs, inputs, process interfaces)	831-ANN (aluminum housing): explosion-proof field device or 831-SNN (stainless steel housing): explosion-proof offshore device zone 1	aluminum housing: explosion-proof field device FM
measurement				
measurement principle	transit time difference correlation principle, automatic NoiseTrek selection for measurements with high gaseous or solid content			
flow direction	bidirectional			
synchronised channel averaging	x (2 measuring channels necessary)			
flow velocity	m/s measuring range: 0.01...25			
repeatability	0.15 % MV ±0.005 m/s			
fluid	all acoustically conductive liquids with < 10 % gaseous or solid content in volume (transit time difference principle)			
temperature compensation	corresponding to the recommendations in ANSI/ASME MFC-5.1-2011			
measurement uncertainty (volumetric flow rate)				
measurement uncertainty of the measuring system ¹	±0.3 % MV ±0.005 m/s			
measurement uncertainty at the measuring point ²	±1 % MV ±0.005 m/s (see also graphical representation)			
transmitter				
power supply	20...32 V DC, U _m = 120 V		<ul style="list-style-type: none"> • 100...230 V/50...60 Hz or • 20...32 V DC 	
power consumption	W	< 4	< 8	
number of measuring channels	1, optional: 2			
damping	s	0...100 (adjustable)		
measuring cycle	Hz	100...1000 (1 channel)		
response time	s	1 (1 channel), option: 0.02		
housing material	aluminum housing: cast aluminum EN AC 44200 mod, special heavy-duty coating (C5 according to EN ISO 12944) stainless steel housing: stainless steel 316/316L (1.4401, 1.4404, 1.4432)			cast aluminum EN AC 44200 mod, special heavy-duty coating (C5 according to EN ISO 12944)
degree of protection	IP66			TYPE 4X/IP66
dimensions	mm	see dimensional drawing		
mounting position	831-A*F (Profibus PA, FF H1), 831-S** : nameplate faces upwards		-	
weight	kg	aluminum housing: 6.5, stainless steel housing: 15.6		
fixation	wall mounting, 2" pipe mounting			
ambient temperature	°C	aluminum housing: <ul style="list-style-type: none"> • -40...+60 • 831-A*F (Profibus PA, FF H1): -40...+50 (< -20 without operation of the display) stainless steel housing: <ul style="list-style-type: none"> • -20...+60 • 831-S*F (Profibus PA, FF H1): -20...+50 	aluminum housing: <ul style="list-style-type: none"> • -40...+60 (< -20 without operation of the display) stainless steel housing: <ul style="list-style-type: none"> • -20...+60 	-40...+60 (< -20 without operation of the display)
display	128 x 64 pixels, backlight			
menu language	English, German, French, Spanish, Dutch, Russian, Polish, Turkish, Italian, Chinese			

¹ with aperture calibration of the transducers

² for transit time difference principle and reference conditions

³ outside the explosive atmosphere (housing cover open)

	FLUXUS F831 (831-AA*, 831-SA*)	FLUXUS F831 (831-AB*, 831-SB*)	FLUXUS F831 (831-ANN, 831-SNN)	FLUXUS F831**-F1N
explosion protection				
• ATEX/IECEX				
marking	<p>CE 0637 Ex II2G II2D Ex db eb ia IIC T6 Gb Ex tb ia IIIC T100 °C Db 831-AAN: T_a -40...+60 °C 831-SAN: T_a -20...+60 °C 831-AAF: T_a -40...+50 °C 831-SAF: T_a -20...+50 °C</p>	<p>CE 0637 Ex II(1)2G II(1)2D Ex db eb ia [ia Ga] IIC T6 Gb Ex tb ia [ia Da] IIIC T100 °C Db 831-ABN: T_a -40...+60 °C 831-SBN: T_a -20...+60 °C 831-ABF: T_a -40...+50 °C 831-SBF: T_a -20...+50 °C</p>	<p>CE 0637 Ex II2G II2D Ex db eb IIC T6 Gb Ex tb IIIC T100 °C Db 831-ANN: T_a -40...+60 °C 831-SNN: T_a -20...+60 °C</p>	-
certification	IBExU20ATEX1103 X, IECEx IBE 20.0015X	IBExU20ATEX1103 X, IECEx IBE 20.0015X	IBExU20ATEX1103 X, IECEx IBE 20.0015X	-
• FM				
marking	-	-	-	<p> NI, Cl. I, II, III, Div. 2, GP A, B, C, D, F, G / T4A Cl. I Div. 1, GP. A, B, C, D / T6 For Group A, conduit seal of connection compartment is required within 18 inches. Cl. II, Div. 1, GP. E, F, G / T6 Cl. III, Div. 1 / T6 T_a = -40°C to +60°C</p> <p> NI, Cl. I, II, III, Div. 2, GP A, B, C, D, F, G / T4A Cl. I Div. 1, GP. B, C, D / T6 Cl. II, Div. 1, GP. E, F, G / T6 Cl. III, Div. 1 / T6 T_a = -40°C to +60°C</p>
measuring functions				
physical quantities	volumetric flow rate, mass flow rate, flow velocity			
totaliser	volume, mass			
calculation functions	average, difference, sum (2 measuring channels necessary)			
diagnostic functions	sound speed, signal amplitude, SNR, SCNR, standard deviation of amplitudes and transit times			
communication interfaces				
service interfaces	measured value transmission, parametrisation of the transmitter: USB ³			
process interfaces	intrinsic safety, max. 1 option: • HART • Profibus PA • FF H1		max. 1 option: • Modbus RTU/RS485 • HART • Profibus PA • FF H1 • BACnet MS/TP	
intrinsic safety parameters	Profibus PA, FF H1: U _i = 24 V I _i = 174 mA P _i = 1044 mW L _i = 10 µH C _i negligible		-	
accessories				
data transmission kit	USB cable			
software	<ul style="list-style-type: none"> FluxDiagReader: reading of measured values and parameters, graphical representation FluxDiag (optional): reading of measurement data, graphical representation, report generation, parametrisation of the transmitter 			
data logger				
loggable values	all physical quantities, totalised physical quantities and diagnostic values			
capacity	max. 800 000 measured values			

¹ with aperture calibration of the transducers

² for transit time difference principle and reference conditions

³ outside the explosive atmosphere (housing cover open)

	FLUXUS F831 (831-AA*, 831-SA*)	FLUXUS F831 (831-AB*, 831-SB*)	FLUXUS F831 (831-ANN, 831-SNN)	FLUXUS F831**-F1N
outputs				
The outputs are galvanically isolated from the transmitter.				
• switchable current output				
			configurable according to NAMUR NE43	All switchable current outputs are jointly switched to active or passive.
number		-	max. 3	
range	mA	-	4...20 (alarm current: 3.2...3.99, 20.01...24, hardware fault current: 3.2)	
Unsicherheit		-	0.04 % v. AW ±3 µA	
active output		-	R _{ext} = 250...530 Ω, U _{opencircuit} = 28 V DC	
passive output		-	U _{ext} = 9...30 V DC, depending on R _{ext} (R _{ext} < 458 Ω at 20 V)	
current output in HART mode		-	option	
• range	mA	-	4...20 (alarm current: 3.5...3.99, 20.01...22, hardware fault current: 3.2)	
• active output		-	R _{ext} = 250...530 Ω, U _{opencircuit} = 28 V DC	
• passive output		-	U _{ext} = 9...30 V DC, depending on R _{ext} (R _{ext} = 250...458 Ω at 20 V)	
• current output				
range	mA	configurable according to NAMUR NE43	4...20 (alarm current: 3.2...3.99, 20.01...24, hardware fault current: 3.2)	-
Unsicherheit		0.04 % v. AW ±3 µA		-
passive output		U _{ext} ≤ 29 V DC, depending on R _{ext} (R _{ext} < 458 Ω at 20 V)		-
current output in HART mode		option		
• range	mA	4...20 (alarm current: 3.5...3.99, 20.01...22, hardware fault current: 3.2)		-
• passive output		U _{ext} = 9...29 V DC, depending on R _{ext} (R _{ext} = 250...458 Ω at 20 V)		-
intrinsic safety parameters		U _i = 29 V I _i = 100 mA P _i = 0.725 W C _i = 1 nF L _i = 50 nH		-
• digital output				
functions		• frequency output • binary output • pulse output	• frequency output • binary output • pulse output	
type		open collector (passive)	open collector (passive)	
operating parameters		8.2 V/30 mA (NAMUR)	8.2 V/30 mA (NAMUR)	
max. values		8 mA at 29 V DC	8 mA at 29 V DC	
frequency output				
• range	kHz	2...10	2...10	
• damping	s	0...999.9	0...999.9	
• pulse-to-pause ratio		1:1	1:1	
binary output				
• binary output as alarm output		limit, change of flow direction or error	limit, change of flow direction or error	
pulse output				
• pulse value	units	0.01...1000	0.01...1000	
• pulse width	ms	0.05...1000	0.05...1000	
• pulse rate		max. 10 000 pulses	max. 10 000 pulses	
intrinsic safety parameters		U _i = 29 V I _i = 100 mA P _i = 0.725 W C _i = 1 nF L _i = 50 nH		

¹ with aperture calibration of the transducers

² for transit time difference principle and reference conditions

³ outside the explosive atmosphere (housing cover open)

	FLUXUS F831 (831-AA*, 831-SA*)	FLUXUS F831 (831-AB*, 831-SB*)	FLUXUS F831 (831-ANN, 831-SNN)	FLUXUS F831**-F1N
inputs				
	not short-circuit proof The inputs are not galvanically isolated from the transmitter.		The inputs are galvanically isolated from the transmitter.	
• temperature input				
number	-	max. 1	max. 1	
type	-	Pt100/Pt1000	Pt100/Pt1000	
connection	-	4-wire	4-wire	
range	°C	-150...+560	-150...+560	
resolution	K	0.01	0.01	
accuracy		±0.01 % MV ±0.03 K at 18...28 °C ±0.01 % MV ±0.03 K ±0.0005 %/K at <18 °C/>28 °C	±0.01 % MV ±0.03 K at 18...28 °C ±0.01 % MV ±0.03 K ±0.0005 %/K at <18 °C/>28 °C	
Kabelwiderstand	Ω	max. 1000	max. 1000	
intrinsic safety parameters	-	U _o = 9.2 V I _o = 25 mA P _o = 0.057 W C _o = 4283 nF L _o = 57 mH	-	
• switchable current input				
	All switchable current inputs are jointly switched to active or passive.			
number	-		max. 2	
accuracy	-		±0.1 % MV ±0.01 mA at 18...28 °C ±0.1 % MV ±0.01 mA ±0.005 %/K at <18 °C/>28 °C	
resolution	µA		0.1	
active input	-		R _{int} = 75 Ω, I _{max} ≤ 30 mA U _{opencircuit} = 28 V (Leerlauf) U _{min} = 21.4 V at 20 mA	
• range	mA		0...20	
passive input	-		U _{ext} = 24 V, R _{int} = 35 Ω, I _{max} ≤ 24 mA	
• range	mA		0...20	
• current input				
number	-	max. 1	-	
accuracy	-	±0.1 % MV ±0.01 mA at 18...28 °C ±0.1 % MV ±0.01 mA ±0.005 %/K at <18 °C/>28 °C	-	
resolution	µA	0.1	-	
active input	-	U _{int} < 20 V, R _{int} ≤ 385 Ω, I _{max} ≤ 40 mA U _{min} = 19.6 V - R _{int} · I	-	
• range	mA	0...20	-	
intrinsic safety parameters	-	U _o = 29.2 V I _o = 88 mA P _o = 0.64 W C _o = 73 nF L _o = 4.1 mH	-	

¹ with aperture calibration of the transducers

² for transit time difference principle and reference conditions

³ outside the explosive atmosphere (housing cover open)

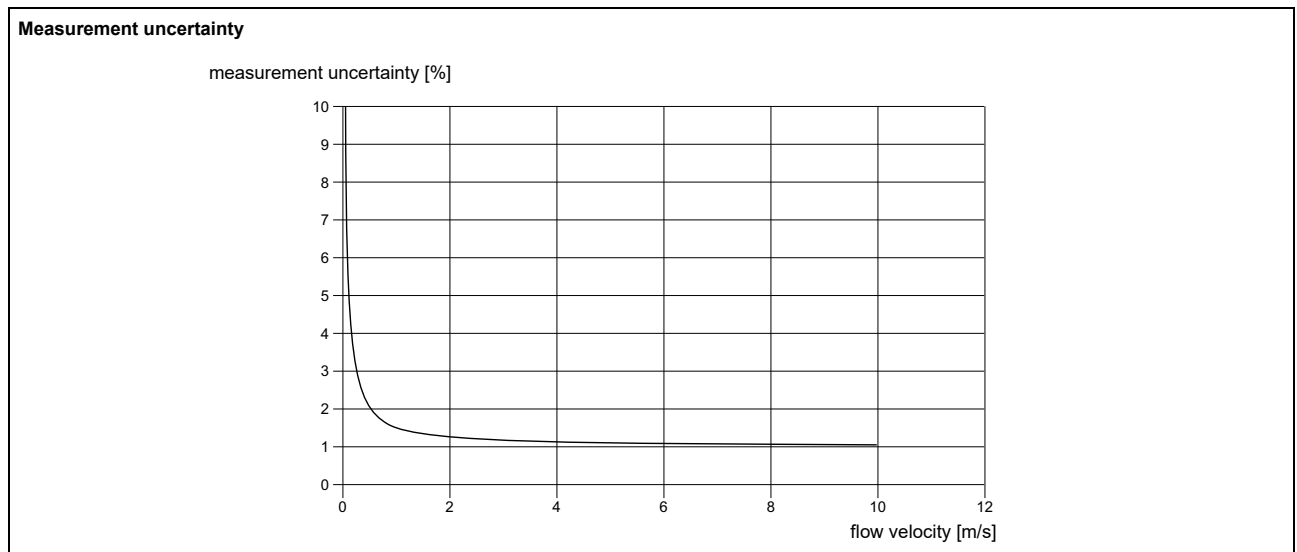

Dimensions

***831 (aluminum housing)**

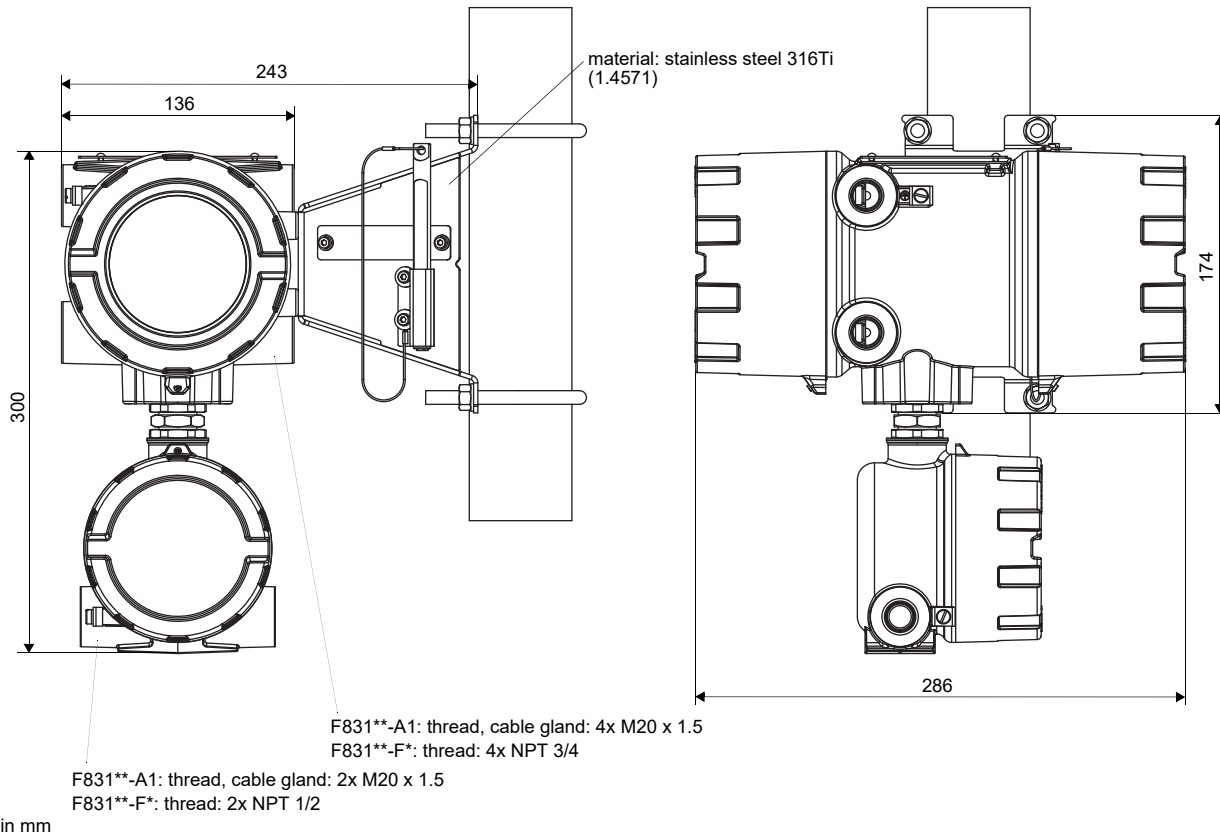

***831 (stainless steel housing)**

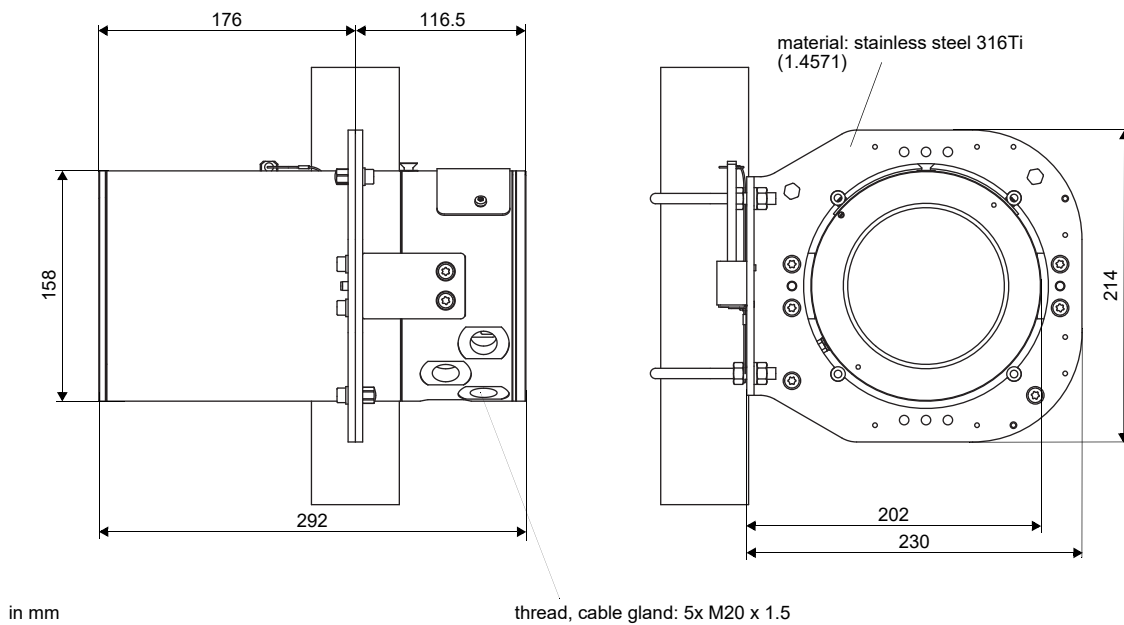

Wall and 2" pipe mounting kit

*831 (aluminum housing)

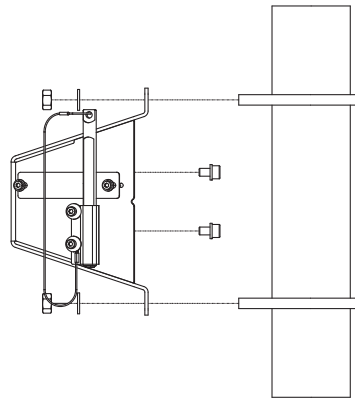

*831 (stainless steel housing)

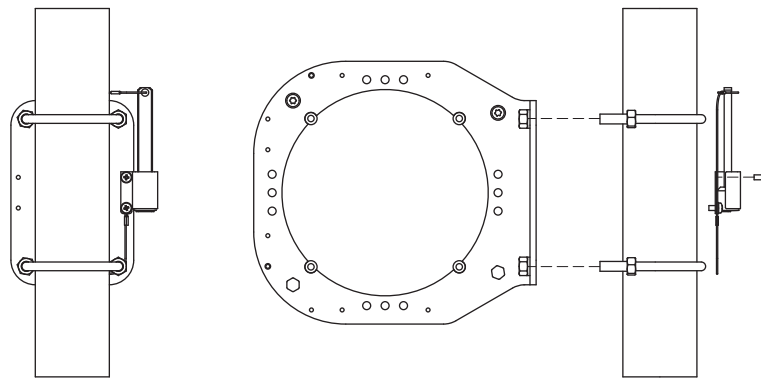

Storage

- do not store outdoors
- store within the original package
- store in a dry and dust-free place
- protect against sunlight
- keep all openings closed
- storing temperature:
 - aluminum housing: -40...+60 °C
 - stainless steel housing: -20...+60 °C

Terminal assignment

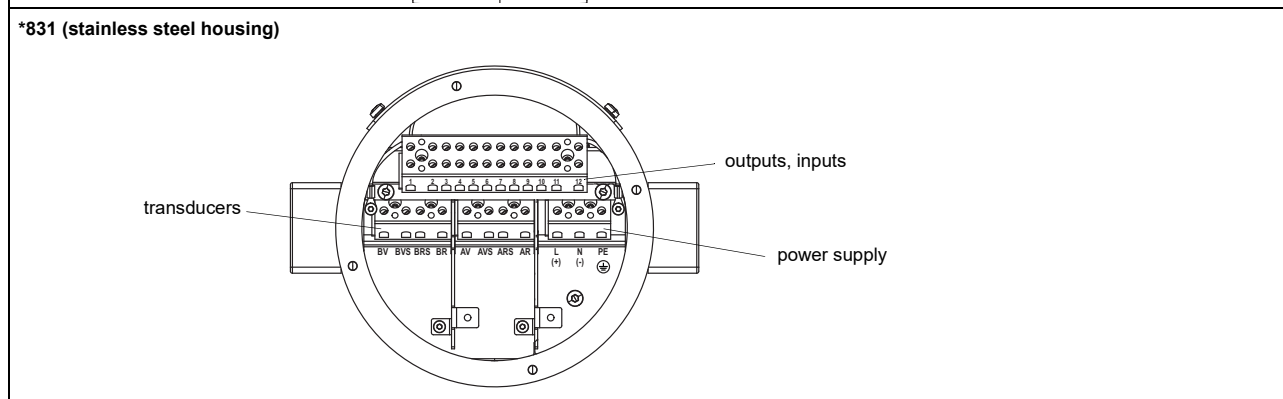
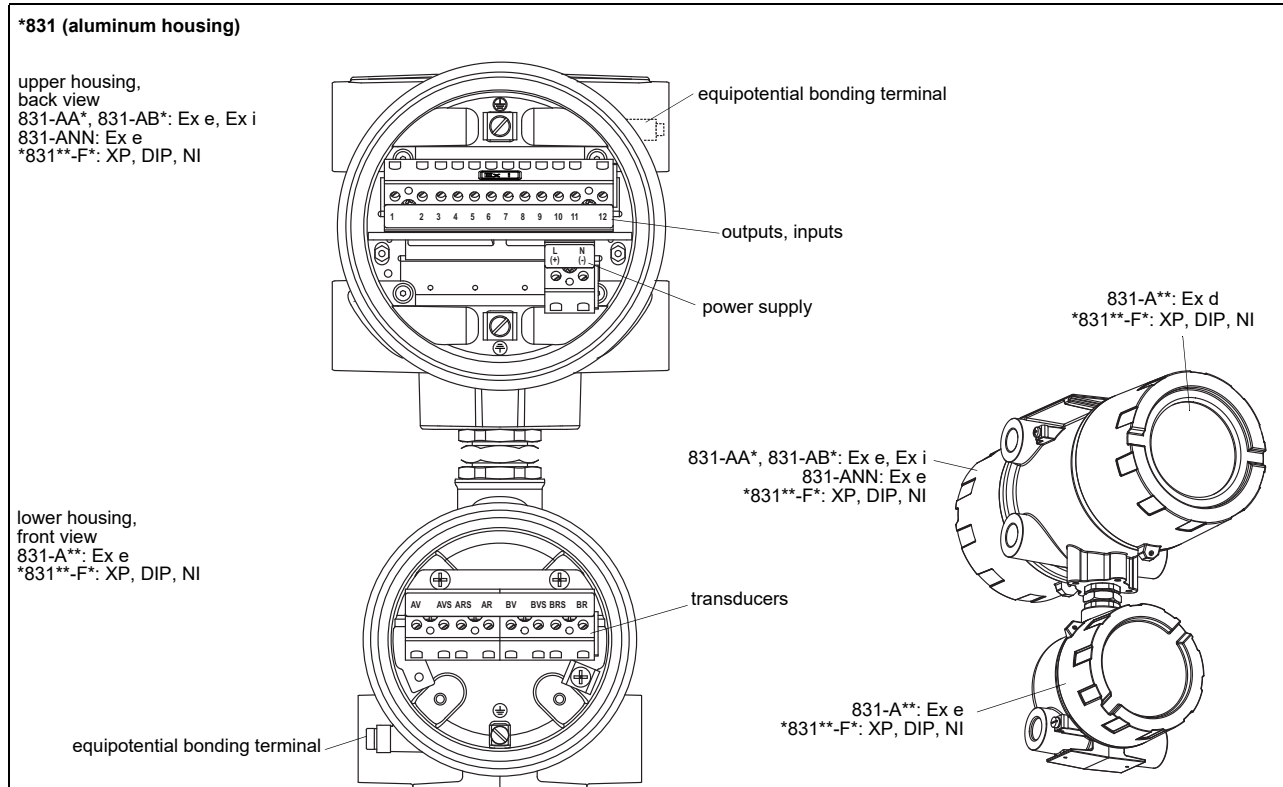

power supply¹

AC		DC	
terminal	connection	terminal	connection
L	outer conductor	(+)	+
N	neutral conductor	(-)	-
	protective conductor		

¹ cable (by customer): e.g. flexible wires, with insulated wire ferrules, wire cross-section: 0.25...2.5 mm²

transducers, extension cable

measuring channel A		measuring channel B		transducer
terminal	connection	terminal	connection	
AV	signal	BV	signal	↑
AVS	internal shield	BVS	internal shield	↑
ARS	internal shield	BRS	internal shield	↑
AR	signal	BR	signal	↑
cable gland	external shield	cable gland	external shield	↑ ↑

outputs, inputs^{1, 2}		
terminal	connection	
depending on configuration	current output, digital output, current input	
3, 4, 5, 6	temperature input	
11+, 12-	passive current output/HART	
11-, 12+	active current output/HART	
11, 12	Modbus RTU, FF H1, Profibus PA, BACnet MS/TP	
temperature probe		
terminal	direct connection	connection with extension cable
3	red	blue
4	red	grey
5	white	white
6	white	red
USB	type C Hi-Speed USB 2.0 Device	service (FluxDiag/FluxDiagReader)

¹ cable (by customer): e.g. flexible wires, with insulated wire ferrules, wire cross-section: 0.25...2.5 mm²

² The number, type and terminal assignment are customised.

Transducers

Overview

Shear wave transducers

	technical type						
	G	K	M	P	Q	S	
zone 1 normal temperature range	CDG1N81 CLG1N81	CDK1N81 CLK1N81	CDM2N81 CLM2N81	CDP2N81 CLP2N81	CDQ2N81 CLQ2N81		
zone 1 IP68	CDG1L11	CDK1L11	CDM2L11	CDP2L11			
zone 1 extended temperature range	CDG1E83 CLG1E83	CDK1E83 CLK1E83	CDM2E85 CLM2E85	CDP2E85 CLP2E85	CDQ2E85 CLQ2E85		
FM Class I Div. 1 normal temperature range	CDG1N62 CLG1N62	CDK1N62 CLK1N62	CDM1N62 CLM1N62	CDP1N62 CLP1N62	CDQ1N62 CLQ1N62		
FM Class I Div. 2 normal temperature range	CDG1N53 CLG1N53	CDK1N53 CLK1N53	CDM2N53 CLM2N53	CDP2N53 CLP2N53	CDQ2N53 CLQ2N53	CDS2N53	
FM Class I Div. 2 extended temperature range			CDM2E53 CLM2E53	CDP2E53 CLP2E53	CDQ2E53 CLQ2E53		
inner pipe diameter d							
min. extended	mm	400	100	50	25	10	6
min. recommended	mm	500	200	100	50	25	10
max. recommended	mm	4000	2000	1000	400	150	70
max. extended	mm	6500	2400	1200	480	240	70
pipe wall thickness							
min.	mm	11	5	2.5	1.2	0.6	0.3

for further data see Technical specification TS_F8xx-transducersVx-xxx_Leu

Transducer mounting fixture

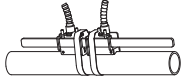
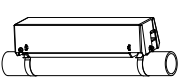
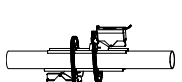
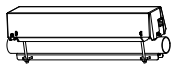
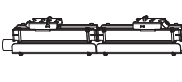
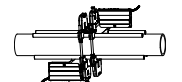
Variofix L	Variofix C	PermaFix	transducer box WI for Wavelinjector with chains
	 transducer frequency S		
	Variofix C with bolt mounting plates	PermaFix with bolt mounting plates	transducer box WI for Wavelinjector with threaded rods
	 outer pipe diameter: VCM: max. 46 mm VCC: max. 36 mm		 outer pipe diameter: 35...380 mm

for further data see Technical specification TS_F8xx-transducersVx-xxx_Leu

Coupling materials for transducers

	normal temperature range		extended temperature range			Wavelinjector	
	< 100 °C	< 170 °C	< 150 °C	< 200 °C	200...240 °C	< 280 °C	280...630 °C
< 24 h	coupling compound type N or coupling foil type VT	coupling compound type E or coupling foil type VT	coupling compound type E or coupling foil type VT	coupling compound type E or H or coupling foil type VT	coupling foil type TF	coupling foil type A and coupling foil type VT	coupling foil type B and coupling foil type VT
long time measurement	coupling foil type VT	coupling foil type VT	coupling foil type VT	coupling foil type VT			

for further data see Technical specification TS_F8xx-transducersVx-xxx_Leu

Connection systems

connection system T1		
connection with extension cable	direct connection	transducers technical type
		*****53
<p>JB01</p>		*****8*
<p>JB01</p>		*****L1*
<p>terminal board for junction box (junction box by customer)</p>		*****62

for further data see Technical specification TS_F8xx-transducersVx-xxx_Leu

Temperature probes

PT12N (item number: 770415-6)	PT12N (item number: 770415-7)
<ul style="list-style-type: none"> • Pt100 • clamp-on • -45...+230 °C • ATEX zone 0/1 (intrinsic safety) • for 831-*B* 	<ul style="list-style-type: none"> • Pt100 • clamp-on • -45...+250 °C • ATEX zone 1 • for 831-*NN
	

see Technical specification TS_PTVx-xxx

Annex

Reference conditions

as available at e.g. the test facilities of Physikalisch-Technische Bundesanstalt

measurement principle		transit time difference correlation principle
all uncertainties	%	95
fluid temperature		25 °C ±5 K
ambient temperature		25 °C ±5 K
warm-up time	min	10
flow profile at the measuring point		fully developed, rotationally symmetric
installation		installation according to specifications using the recommended transducers
Reynolds number		> 10 000
pipe diameter uncertainty	%	0.2
pipe wall thickness uncertainty	%	1
circularity tolerance		0.08 % of inner pipe diameter
SCNR	dB	> 48
SNR	dB	> 12